

**1** 200 **DECIDUOUS TREE PLANTING** FOR TREES LESS THAN 80 mm CALIPER N.T.S.

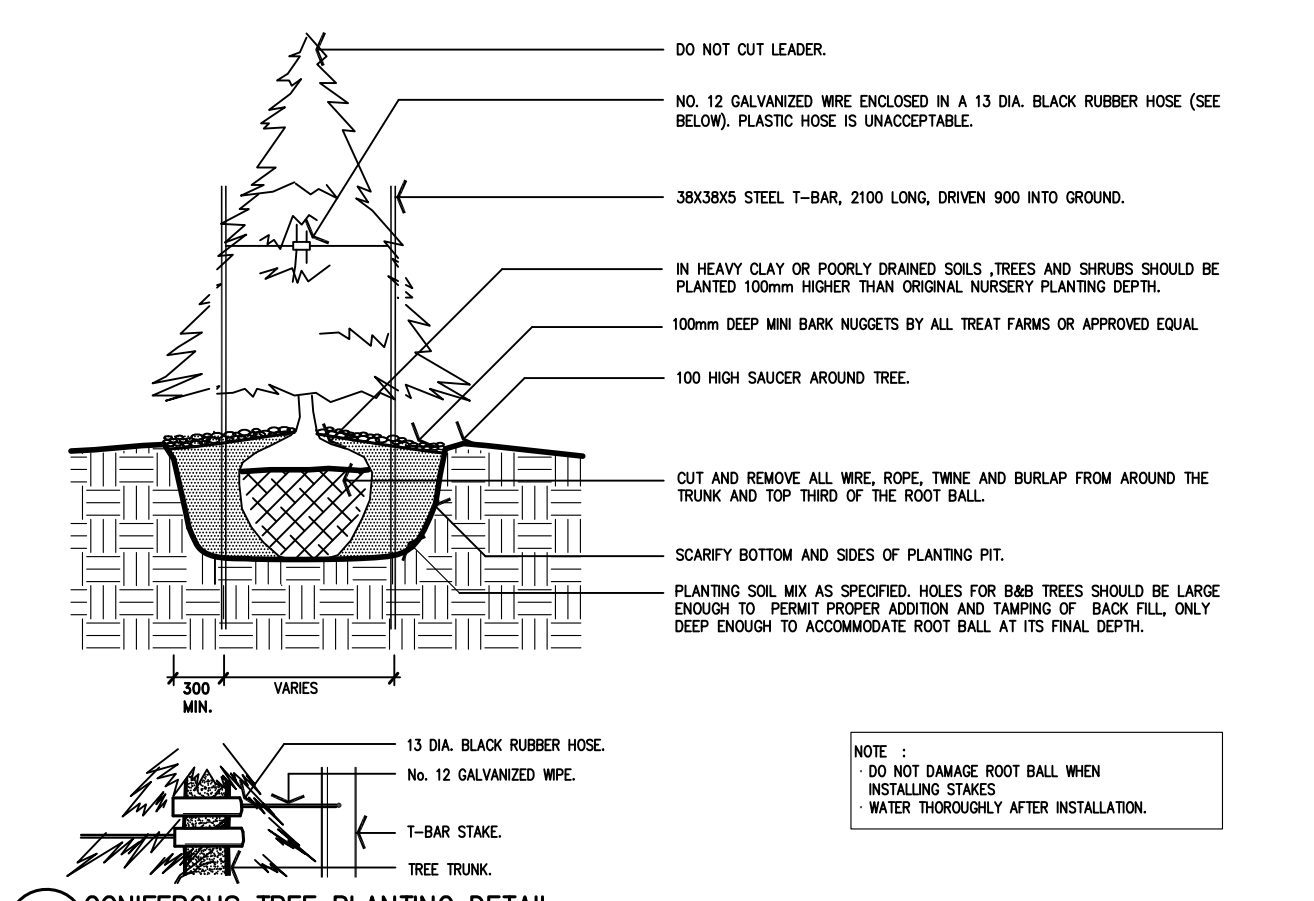

**2** 200 **CONIFEROUS TREE PLANTING DETAIL** N.T.S.

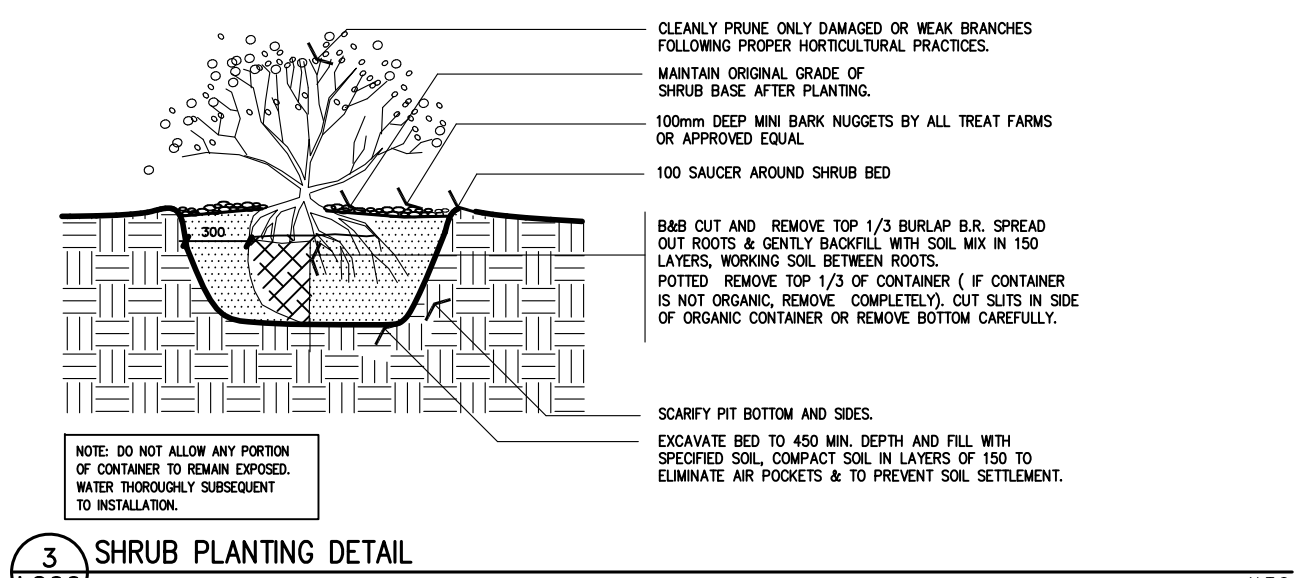

**3** 200 **SHRUB PLANTING DETAIL** N.T.S.

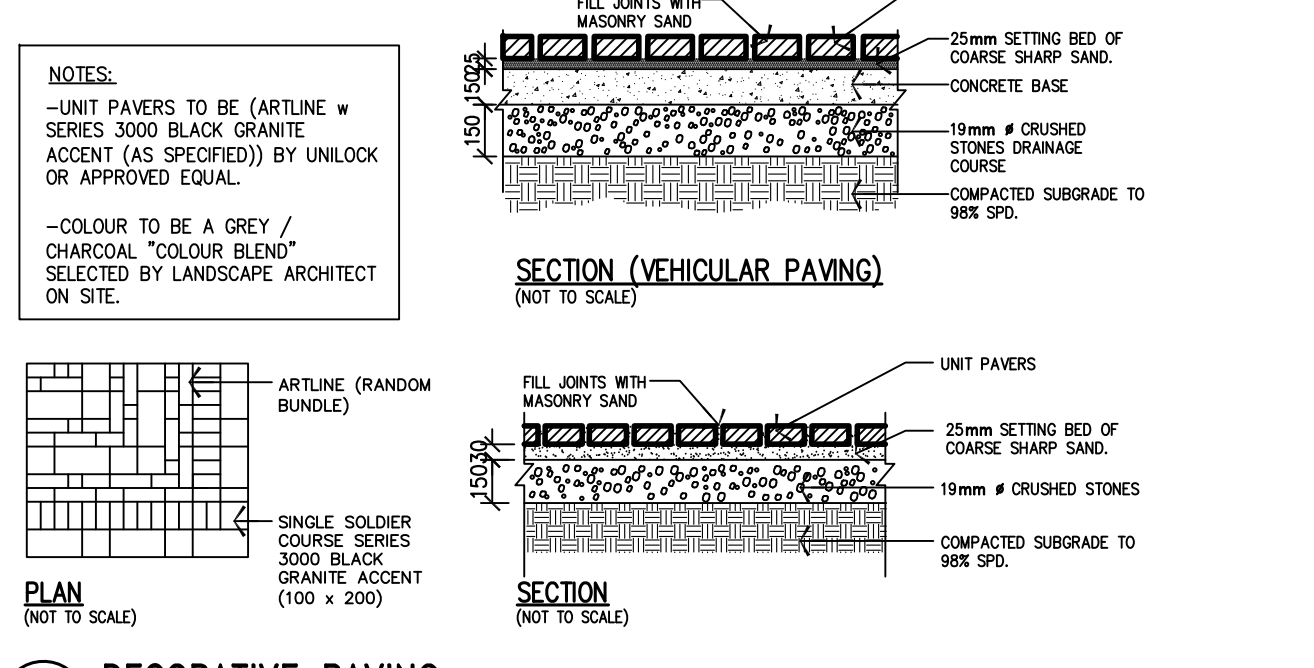

**4** 200 **DECORATIVE PAVING** N.T.S.

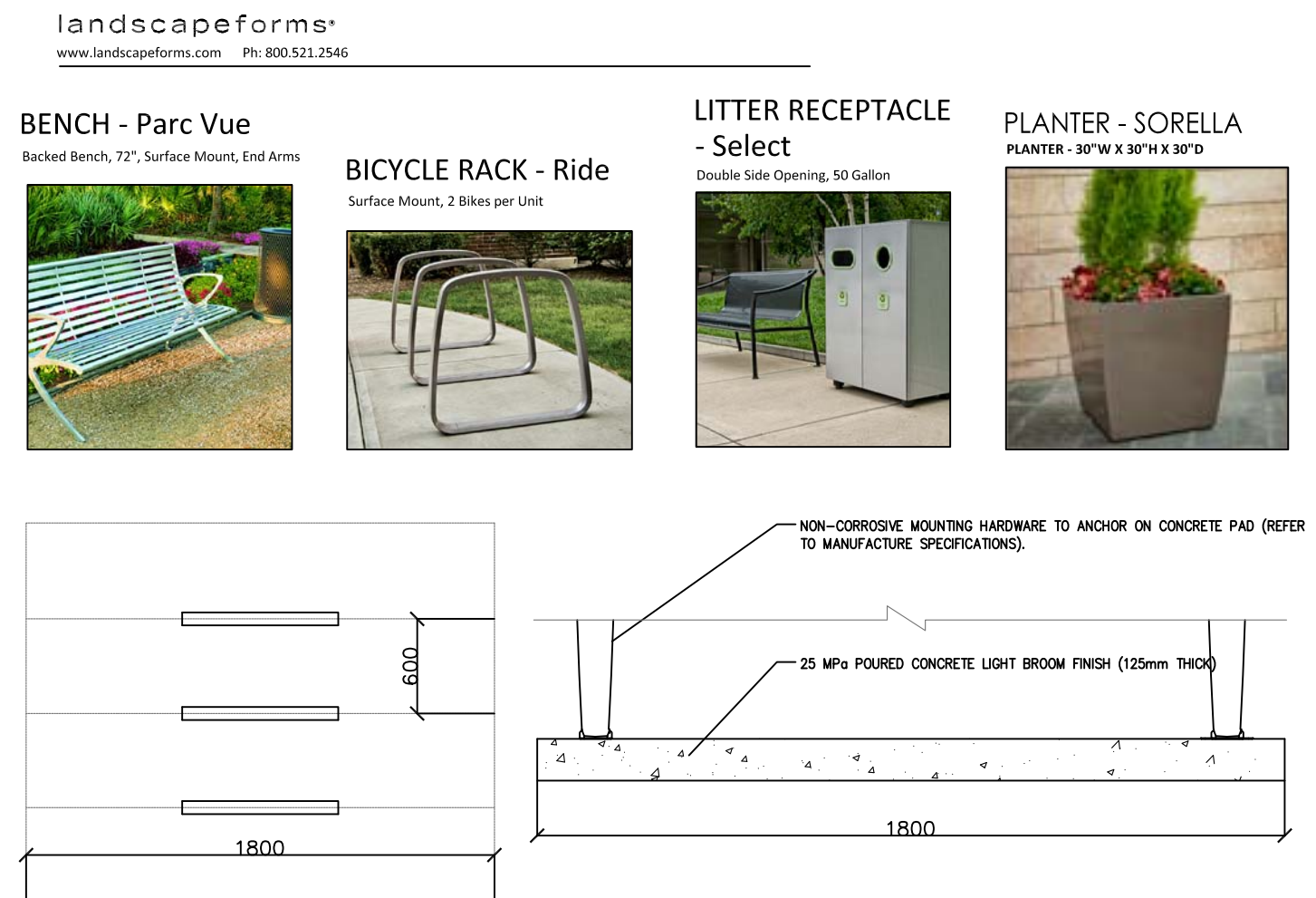

**5** 200 **SITE FURNITURE & BIKE RING MOUNTING** N.T.S.

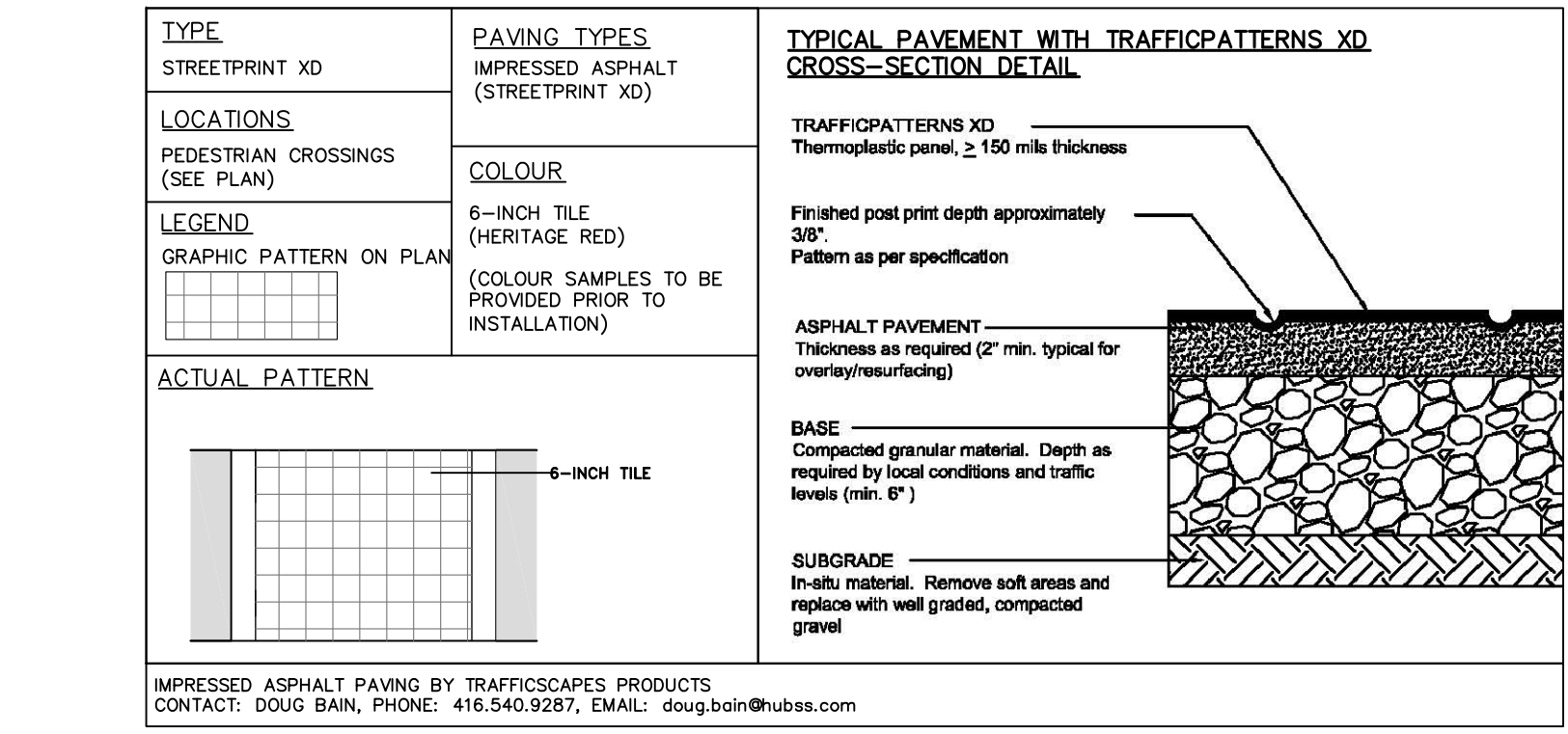

**6** 200 **STREET PRINT XD IMPRESSED ASPHALT CROSSWALK** N.T.S.

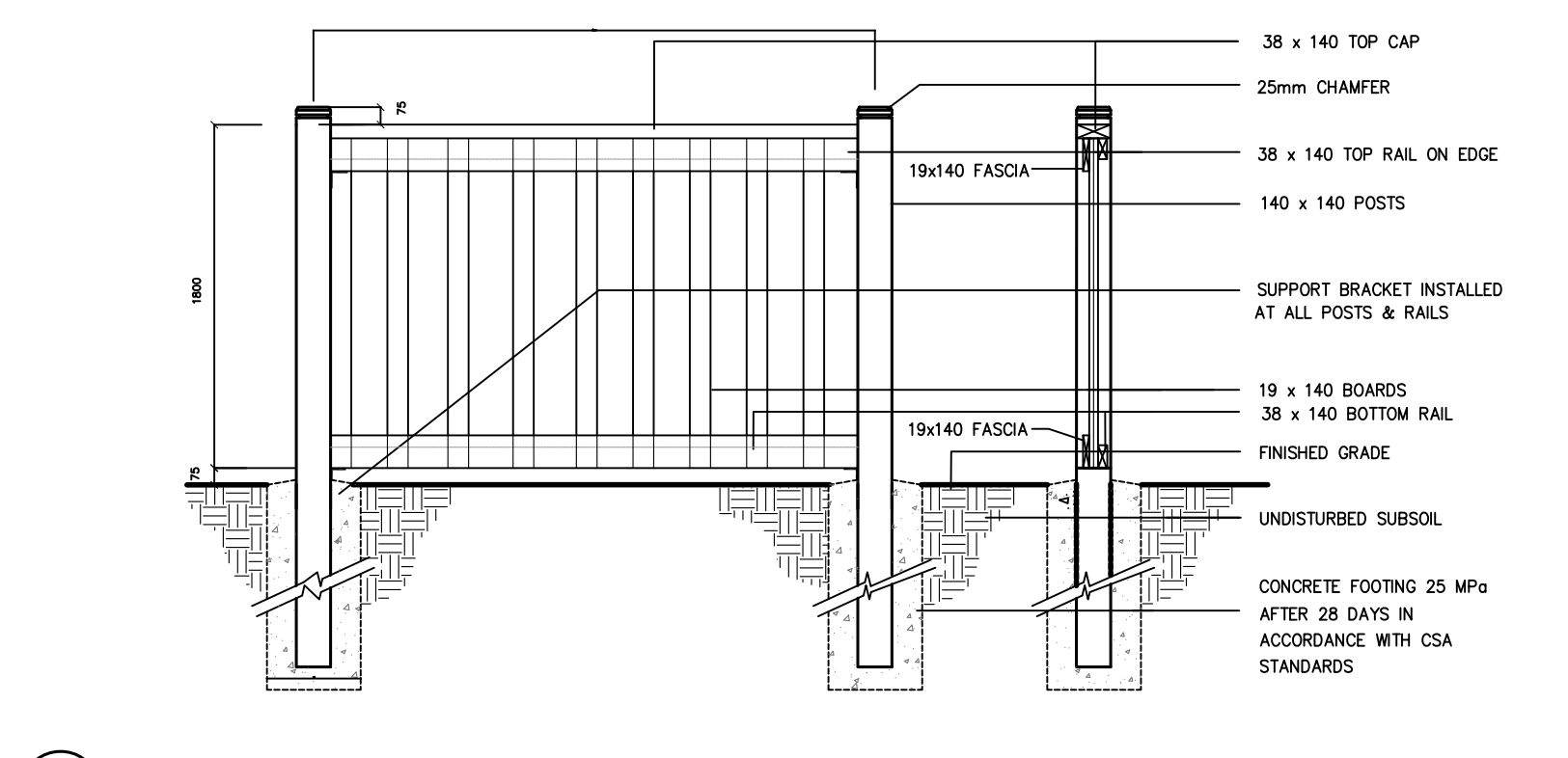
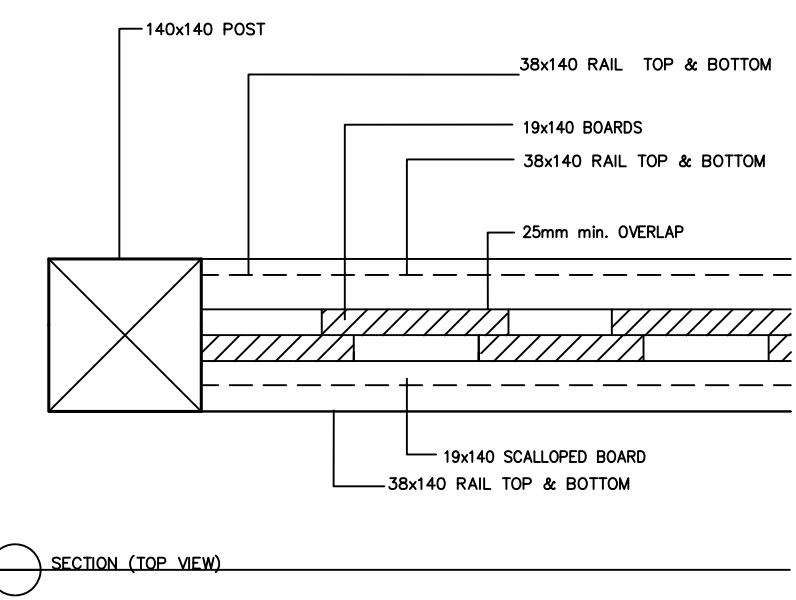

**7** 200 **1.8m HT. WOOD PRIVACY FENCE PANEL** ALL WOOD TO BE PRESSURE TREATED N.T.S.

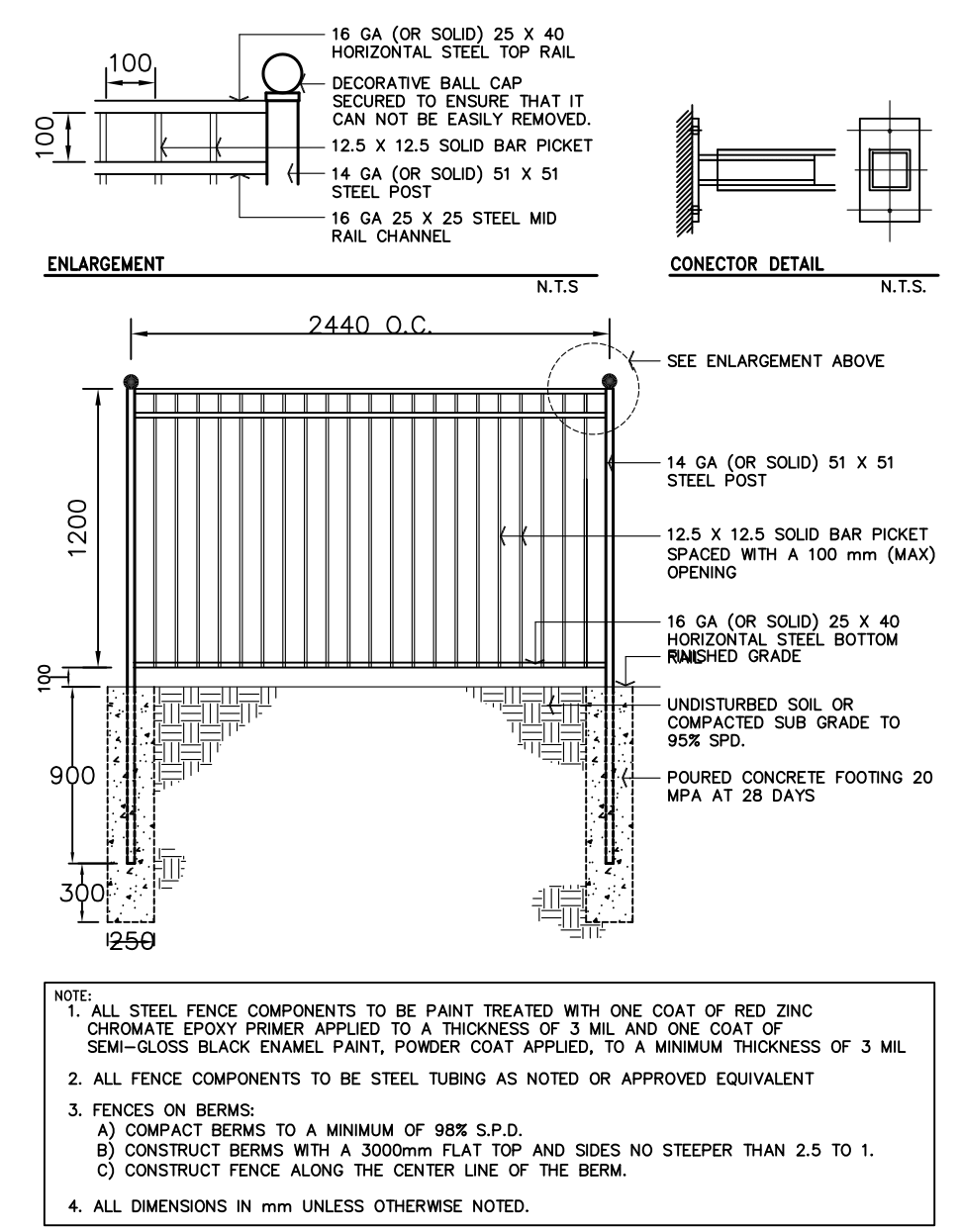

**8** 200 **1.2m Ht. DECORATIVE METAL FENCE** N.T.S.

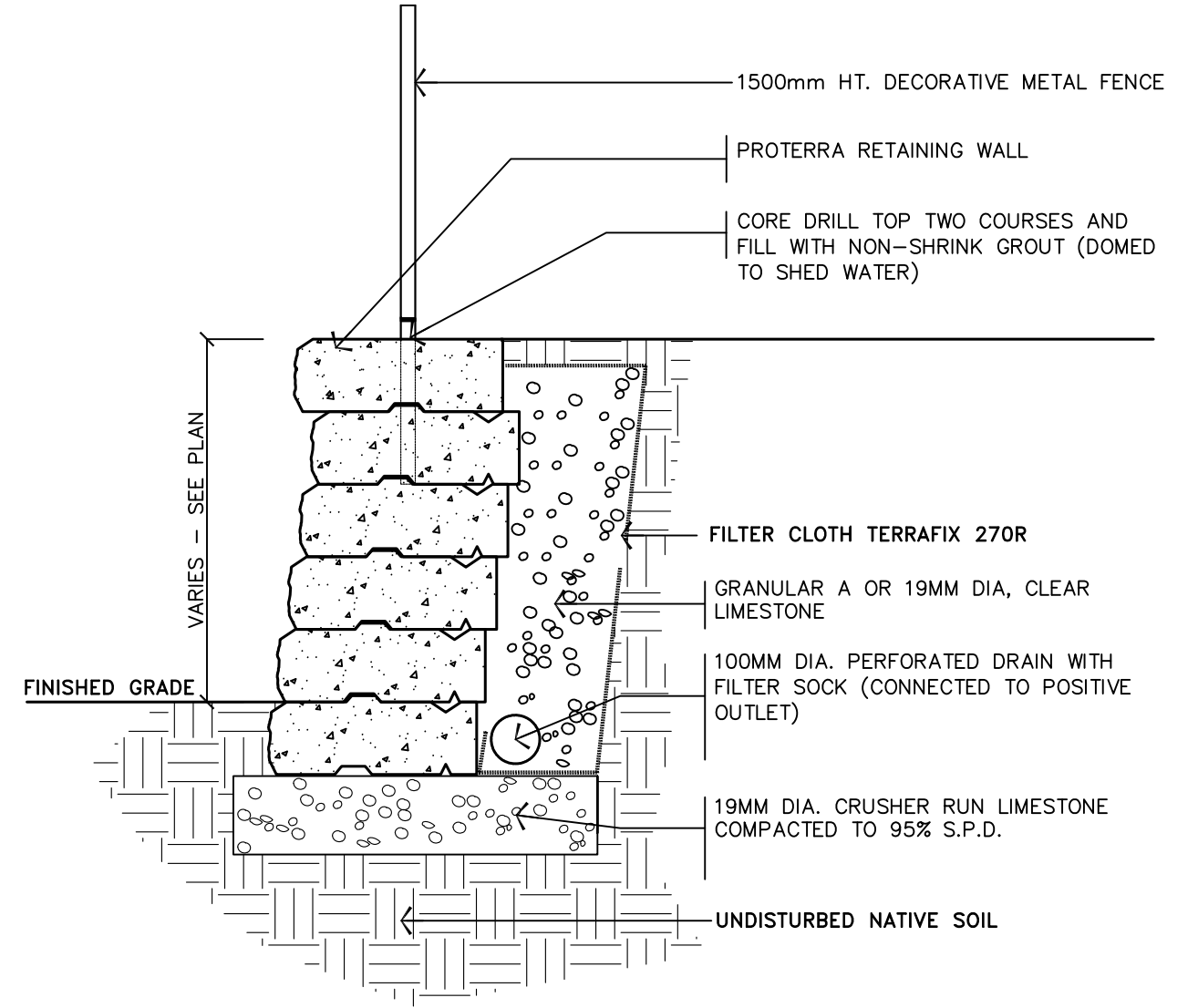

**9** 200 **1.5 HT. BLACK VINYL CHAIN LINK FENCE** N.T.S.

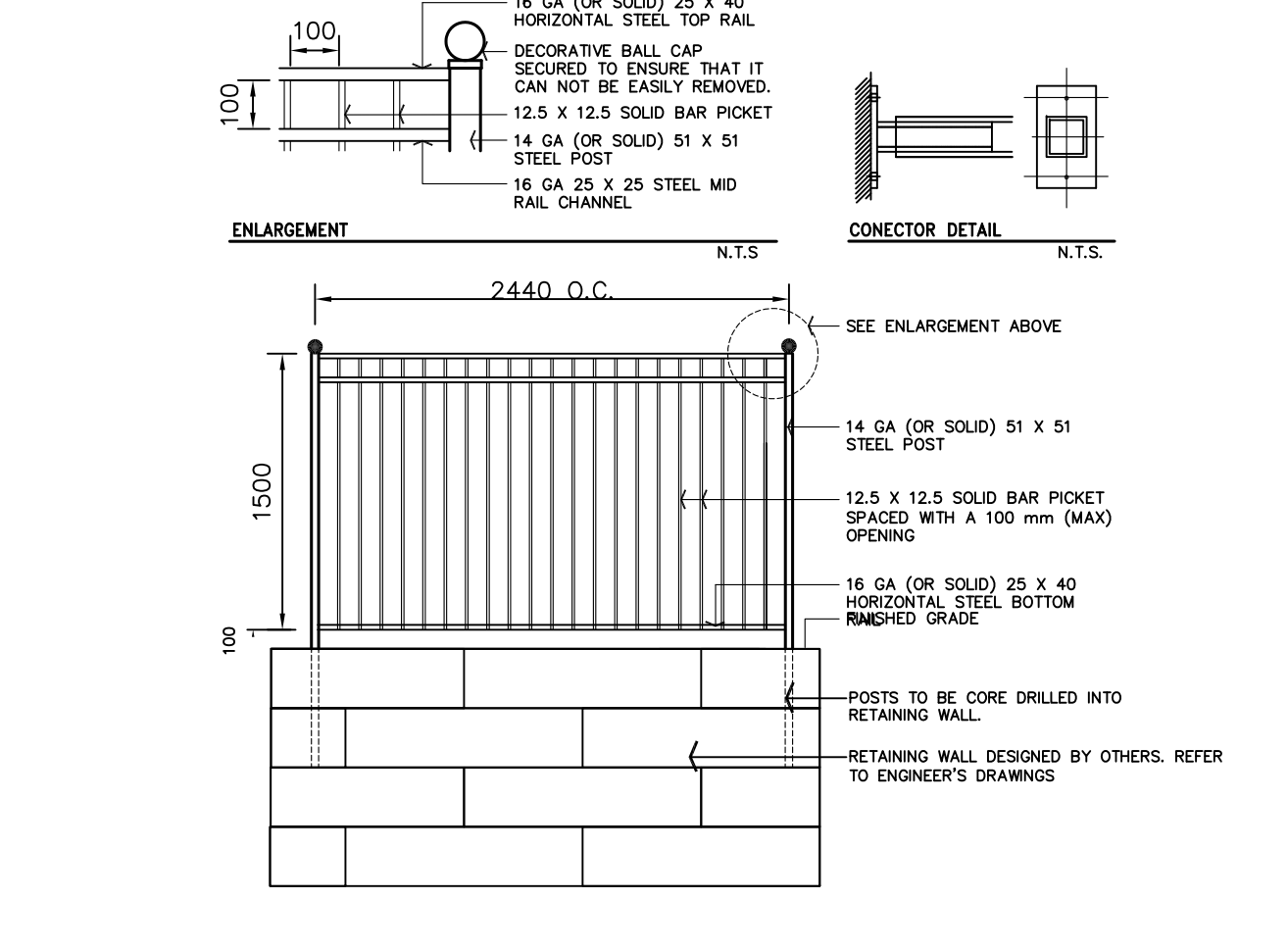

**NOTES:**  
CHAINLINK MESH TO BE 9 GAUGE, BLACK VINYL COATED, 38 (1'-7") WOVEN MESH 1:29M (4'-0") HIGH FASTENED TO THE TOP, BOTTOM AND MID RAILS, AS WELL AS THE LINE POST, STRETCHER BAR AND TENSION WIRE WITH 9 GAUGE GALVANIZED WIRE 457mm (18") O.C.  
FRAMING SHALL BE CONSTRUCTED OF SCHEDULE 40 PRIME GALVANIZED PIPE WITH DIAMETER AS DETAILED ABOVE.  
TERMINAL POSTS- 80mm DIA., LINE POSTS- 60mm DIA., RAILS AND CROSS BRACES- 40mm DIA.  
ALL FENCE COMPONENTS SHALL BE PAINT TREATED WITH ONE COAT STERLING RED PRIMER #1734, FOLLOWED BY ONE COAT STERLING SEMI-GLOSS BLACK ENAMEL #3913, BY ELECTROSTATIC PROCESS.  
ALL GIVEN DIMENSIONS ARE IN MILLIMETRES.

**9** 200 **1.5 HT. BLACK VINYL CHAIN LINK FENCE** N.T.S.

**GENERAL NOTES**

- VERIFY ALL DIMENSIONS.
- DO NOT SCALE DRAWINGS.
- REPORT ANY DISCREPANCIES, DISCOVERED ERRORS, OR OMISSIONS TO THE LANDSCAPE ARCHITECT BEFORE PROCEEDING.
- IT IS ADVISED THAT CONTRACTORS CONTACT THE LANDSCAPE ARCHITECT PRIOR TO CONSTRUCTION TO ENSURE THE USE OF THE LATEST REVISED DRAWINGS.
- DRAWINGS AND SPECIFICATIONS ARE THE PROPERTY OF THE LANDSCAPE ARCHITECT.



**LEGEND**

No.	DATE	REVISION	BY
4.	JUN. 14, 2019	ISSUED FOR SPA SUBMISSION	M.S.
3.	FEB. 25, 2019	ISSUED FOR SPA SUBMISSION	M.S.
2.	JAN. 23, 2019	ISSUED FOR REVIEW	M.S.
1.	DEC. 04, 2018	ISSUED FOR SPA SUBMISSION	M.S.

It is the responsibility of the Contractor and/or Owner to ensure that the drawings with the latest revisions are used for construction.

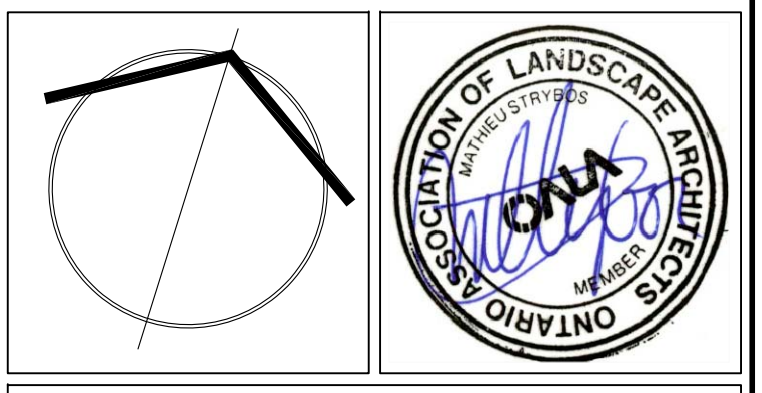

**SBK** 5770 HURONTARIO STREET, SUITE 320  
MISSISSAUGA, ONTARIO, L5R 3G5  
T: 416.695.4949 F: 905.712.3101  
WWW.STRYBOS.COM

**STRYBOS BARRON KING**  
LANDSCAPE ARCHITECTURE

PROJECT: HOTEL TOWNEPLACE SUITES MARRIOTT  
COMMERCIAL/OFFICE BUILDING  
1200 16th AVENUE EAST, OWEN SOUND, ON

DRAWING TITLE: **LANDSCAPE PLAN**

SCALE: 1:250	PROJECT No. 4628
DATE: MAY 2019	DRAWING No. L100
DRAWN BY: J.M.	CHECKED BY: M.S.